



**SHERRILLtree®**  
**TREE GEAR. TREE PEOPLE.**

***Erk Brudi - Andreas Detter - Frank Bischoff***

***Tree bracing- new systems – new techniques***

## 1.0 Introduction

Tree bracing has an indifferent, ambivalent reputation among many arborists. Trained professionals, many of whom were raised by practicing tree workers have come to believe that cabling systems must support the full vertical weight of tree parts, almost as if detached from their parent stem. Often as witnesses of tree/cable failures past, these *engineers by instinct* believe that cable simply can't be too thick or too strong. What they often fail to recognize is that cable can be too rigid.

Traditional tree cabling systems are made of steel components such as wire cables and forged bolts, hardware normally reserved for bracing of rigid structures like water towers and industrial staircases. These rigid materials result in systems with little to no elasticity in an environment of often-high volatility, but more importantly in a patient that grows strength from challenges brought about by varying degrees of wind-induced stress. Like a school bus without suspension, everything seems fine while the bus sits idle in the parking lot.

Further disadvantages of traditional bracing is that hollow stems or branches cannot be sufficiently supported because the residual walls are too thin and may collapse under tension, especially during shock-loads. Drilling through healthy wood, especially in poorly compartmentalizing trees can cause decay and rot.

In the early 1990's, a time when much was known and on the record about cable failures (not all having to do with cable breakage), new concepts were developed for cabling to allow a more tree-friendly approach.

## 2.0 New synthetic materials

In the late 80's to early 90's there was significant investigation and discussion about what best synthetic materials may suit supplemental support for tree cabling. Of greatest importance were strength and elastic recovery.

**Table 1** Properties of the most common synthetic fibres used in tree cabling.  
Source; Jahrbuch der Baumpflege 1998; SCHRÖDER et.al.

Material	Polyester	Polyamid	Polypropylene	
			monofile	multifile
Brief name	PES	PA	PPD	PPM
Knot stability in % of output strength	50-60	50-60	35-50	35-50
Strength reduction caused by water	0 %	10-max. 30%	0 %	0 %
Creeping characteristics at high long-time stress	Almost 0	1-2 %	3-5 %	3-5 %
Friction strength	excellent	excellent	satisfactory	satisfactory
UV- resistance	excellent	good	only when blackened	only when blackened
Resistance against acids	Sensitive to certains	Sensitive to certains	excellent	excellent
Resistance against Alkalines	Excellent against weak ones's	Excellent against weak alkaline	Excellent against certain	Excellent against certain
Melting temperature	260 ° C	215-220 ° C	170 ° C	170 ° C
Distortion temperature	225 ° C	170-220 ° C	140 ° C	140 ° C

Two of the materials were chosen by diverse manufacturers; Polypropylene and Polyester.

Tests after five years in use revealed that Polyester ropes did not reach the durability of the theoretically more sensitive Polypropylene ropes (SCHRÖDER 1997; BRUDI, LESNINO, SPIESS 1999).

The advantage of both materials in comparison to steel cables had to do with shock absorbency, allowing trees to swing freely during gentle wind gusts. This kind of easy and light tree movement is called „low load oscillation“. Both systems are non-girdling due to the use of inserts (cobra) or wide belts (Osnabrucker) which widen the rope diameter like a snow shoe to reduce surface pressure on the bark.

## 2.1 Advantages of modern, synthetic fibre-based bracing systems:

- belts and the stem surrounding cobra system can be used for hollow branches and stems as well because the load bearing is distributed over the full contact surface.
- Shock loading is avoided due to the flexibility of the synthetic fibres.
- The creation of reaction wood is not disturbed
- No drilling - no injury
- Easy and quick installation (Quick splice)
- Automatically lined up in the load direction

## 2.2 Disadvantages of modern, synthetic fibre-based bracing systems:

- Rigid bracing with pre-stressed cables is not possible

## 2.3 Introduction of two systems and their pros and cons

### Osnabrücker System

This system developed by Schröder consists of a belt with varying breaking strengths from 2,8 - 24 tons and PE-ropes with strengths from 4,1 – 7,6 tons.

The belt is attached around the stem and is fixed by a flexible rubber band which allows some secondary growth. The rope is eye-spliced by taping it to a steel fid which is pushed through the hollow braid body of the remaining rope.

Fig. 1 source: Meyerdiercks

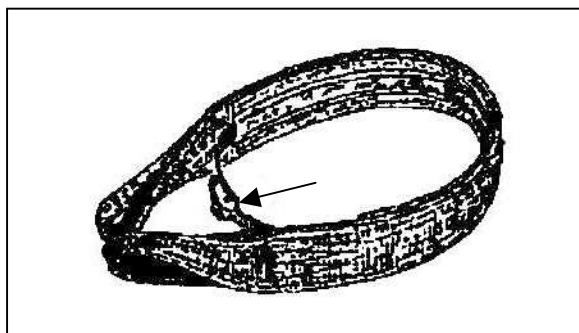

The belt width varies according to the breaking strength from 65-120 [mm]. Inside the belt is a rubber band which can be used when crotches are not available. The rope is fed through eyes in the slings. For chafing protection the sling is covered with a hose.

Fig. 2

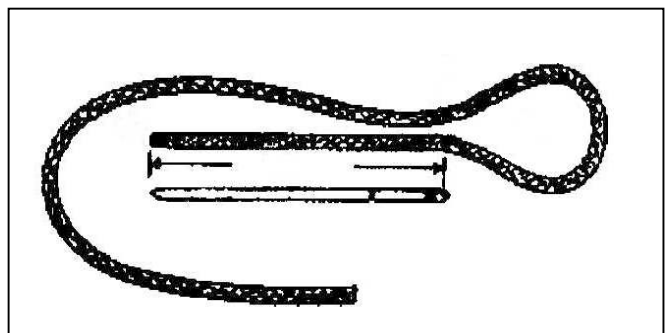

The hollow braid rope is soft. For Splicing, a metal fid is necessary. If spliced as a loop the breaking strength can be nearly doubled from 4,1 up to 7,6 tons (metric).

## 2.4 Cobra system

This system is available in three categories:

- cobra mini (breaking strength 0,6 tons) as a support system for transplants and orchard trees
- cobra standard (Breaking strength 2 tons) as a standard support for most applications
- cobra plus (breaking strength 4 to) as heavy duty system for the support of thick stems and branches, which exceed 50 cm in diameter.

It consists of a hollow braid PP rope, a shock absorber, inserts, a friction sleeve and end caps.

Fig. 3

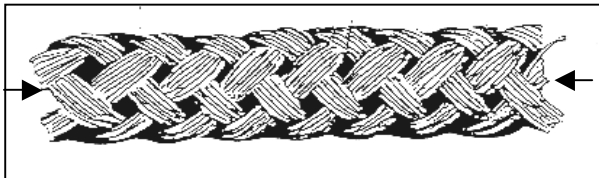

The monofilament cobra propylene rope can be used as hollow rope because of its braiding. The diameter can be expanded through contraction.

Fig. 4

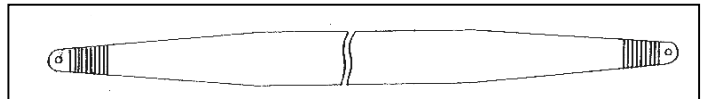

The expansion insert is inserted into the hollow braid rope in the vicinity of the girdling. Expansion of the rope in this area greatly reduces surface pressure.

Fig. 5 source: pbs

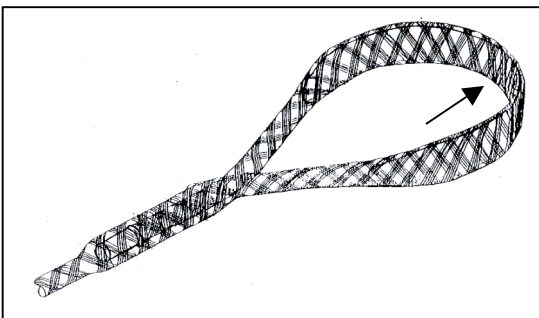

This connection type is called a Quick Splice whereas the rope is fed into itself without the need of tools or a fid. To avoid chafing of rope the eye area is inserted through a friction sleeve tube.

Fig. 6 source: pbs

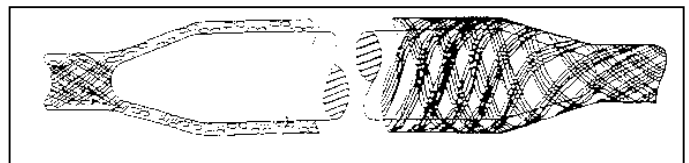

The shock absorber is the main difference between the cobra system and other cabling systems available. The shock absorber is made of a special rubber mixture. Its function is to leave enough motion space at minor oscillations of the branches and stems. Compensation wood can only be created by permanent stimulation, thus, the living tissue is animated to develop more self-stability.

Fig. 7 source: pbs

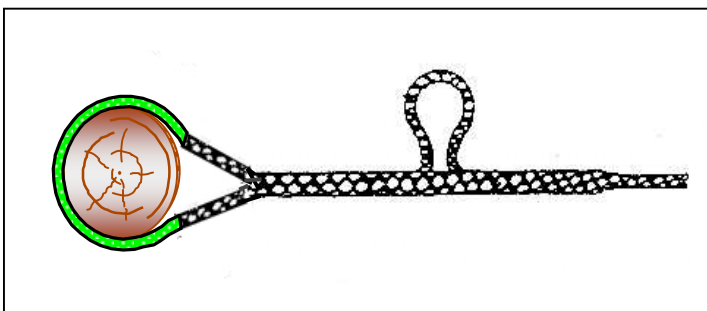

The friction sleeve (green) protects the tree and rope from chafing. Using a loop eases the handling during installation. Colour coded end caps allows easy identification of installation date.

## 2.5 Pros and cons

Tab. 2

Properties	Osnabrücker System (PE Rope)	Cobra system (standard)
Durability strength loss after 5 years in use	50%	10 %
Recyclability	non recyclable	1: 1 easy recycling
Low load oscillation	none	yes, due to shock absorber
max Breaking strength	up to 14 tons	up to 7,5 tons (if doubled)
Elasticity	10,5 %	7,5 % (without shock absorber)
Rope type	PE (hollow braid)	PP (hollow braid)
Cambial pressure	none	none
Cost of material (Germany)	30 – 90 €	30 – 65 €
Cost of storage	high, due to individual circumferences differnt belts sizes	low, due wrapping around
Flexibility of use on site	low, due to individual belt sizes	low, fully competible to all circumferences
Installation time	approx. 20 min/ connection	approx. 20 min/ connection
Monitoring of time of installation	check records	color coded end caps

### 3.0 Bracing and Physics

Common regulations and specifications require to install bracing systems in the upper third of the crown. This is necessary due to the fact that in this region the highest wind forces occur. Bracing close to the point where the forces occur requires less breaking strength. Any lever over the load center stresses the cable and rope connection.

Fig. 8

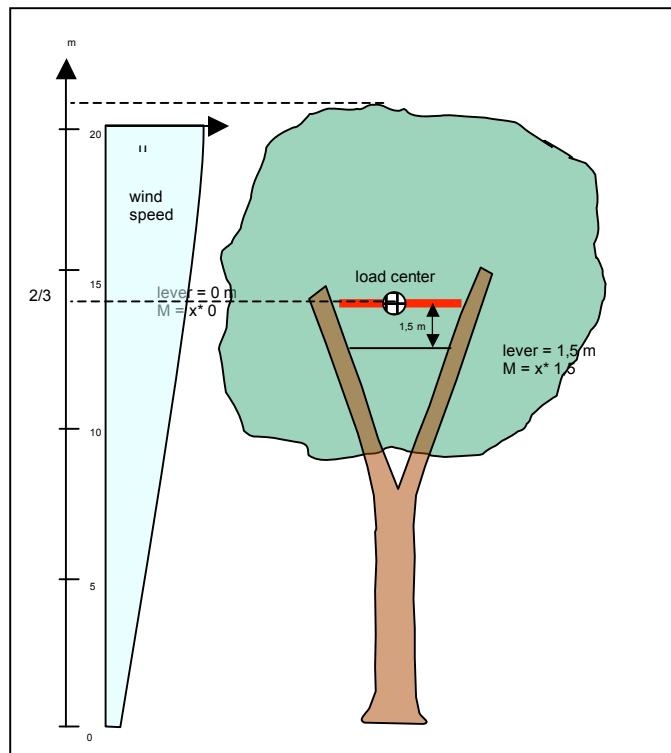

Another fist rule is to multiply the diameter of the stem at its base by 20, this value should be

Fig. 9

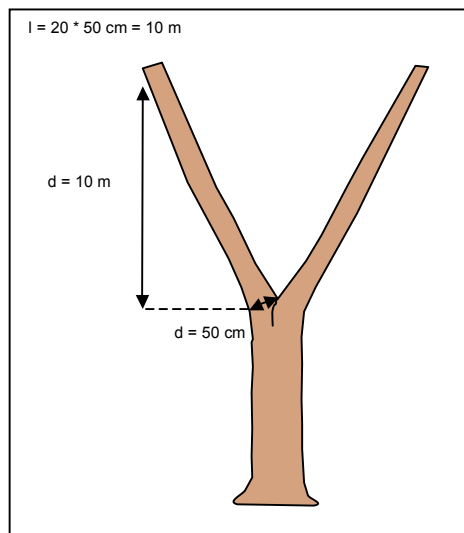

the 1: 20 fist rule

### 3.1 Bracing and rope/cable angles

Ropes which are installed at an angle ( e.g. to support a jutting out branch) require more strength due to the fact that the breaking strength in ropes and cables is measured horizontally. Any deviation from that direction leads to an increasing required force. The steeper the angle the more breaking strength is necessary.

The calculation is based on the cosines function of the diverted angle, e.g at an angle of 30° the required strength of the cable increases 14%, 45° = 30% and 60° = 50%.

Fig. 10

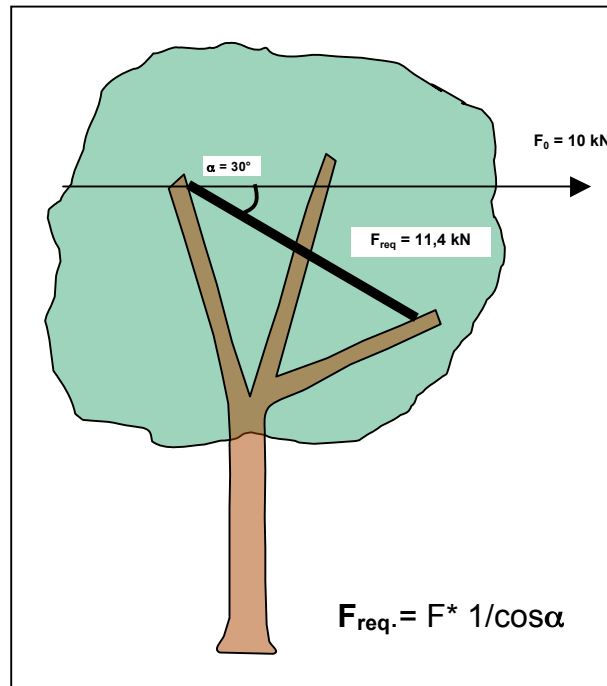

### 3.2 Bracing and rope/cable strength

#### steel or synthetic – rigid or dynamic?

Synthetic fibres should never be installed under tension or be prestressed because they might creep. Practical experience has shown that in more than 95% of the cases the use of synthetic fibers is more than adequate for tree support.

Rigid steel ropes can be used when crotches are severely damaged, showing cracks or open fissures. In such cases the crown is not allowed to move in the wind and has to be kept tight in position – therefore a prestressed cable which is designed for static permanent loading is required.

If the 1: 20 rule can be kept the breaking strength in Tab.3 gives a brief overview how the rope should be dimensioned. Rigid steel cables have breaking strength that can be very high depending on their diameter. The whole system itself, consisting of cable, clamps, washers and eyebolts however has its weak spots, which are the threads of the steel bars and the eye bolts. They are the weakest link in the chain and reduce the breaking strength of the overall system, depending on the steel type, down to 10-20% of the breaking strength of the cable. J-lags can be even weaker, depending on wood structure.

Tab. 3 Rope strength and stem diameters regarding the 1: 20 rule

Diameter of stem at fork in cm	required rope strength in tons (metric)
up to 30 cm	1,3
up to 50 cm	2,0
over 50 cm	3,0 -4,0

If the 1: 20 rule cannot be kept due to lacking opportunities to install the system at the appropriate height the levers over the attachment points increase and the rope strength should be higher.

„In general two approaches for the dimensioning of bracing systems are possible:

1.

„The load bearing capacity of the stems or branches should be taken into account.

The first consideration is to calculate how much load a branch or stem of the referring tree can take, at a certain diameter, before it fails when attaching a rope at a certain height.

A realistic point to start with is the attachment of a rope at a height of 10 m. The limit of the rope dimension is the limit of elasticity of the referring tree species. In Fig. 11 it clearly can be seen that at an oak 2 tons are sufficient enough to break a branch of a diameter of 42 cm. At horse-chestnut the same force leads even to breaking failure of a branch of 52 cm.

If a branch is only 30 cm in diameter already 0,8 tons lead to failure (oak) and at 0,5 tons a branch of a „standard tree“ can be broken off.

With every meter of additional height of the attachment point the available safety is increasing by 10%. An extension of the lever of up to 50% at a unchanged load of 2 tons equals an increase of the load bearing capacity of 50% up to 3 tons (at a fixed lever of 10 m).

Due to the fact that the length of stems increase with the growing stem diameter it is possible to compensate this by attaching the connection higher in the tree.

It seems quite obvious that a 2 ton system matches well with most situations.

Fig. 11 source: Wessolly

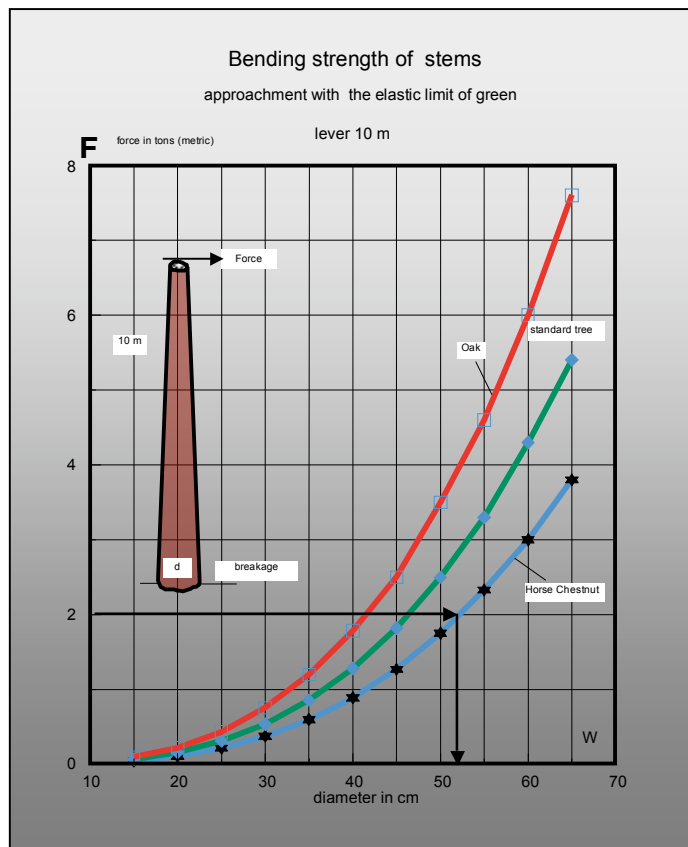

2.

The experience of 40 years of bracing with rigid steel bars and steel cables should be kept in mind as well.

At the formerly installed rigid systems the single components had a lot less load bearing capacity. As in a chain it is enough to watch the weakest link and the demonstration of its worth in tough circumstances of daily use. The weakest link was the thread of the eye bolt which, at a diameter of 12 mm had a small breaking strength of only 1,2 tons whereas the cable had a strength of 12 tons. This construction was not optimized especially when kept in mind that in stiff rigid steel cables a lot higher forces occur when stopped abruptly (shock loading), than in synthetic fibres. A healthy sound stem is seldom stressed so much that it breaks in a heavy storm. In

most of the cases it is oversized, i.e. it can bear higher loading and has reserves. If its load bearing capacity is exhausted it should not be connected to another weak neighbour tree. Empiricism shows that hundred of thousands bracing systems which were installed already rarely failed due to high stresses in storms and therefore it can be concluded that mostly only small forces occur in tree crowns.“

### 3.3 Influence of stem diameter in co dominant stems

Fig. 12

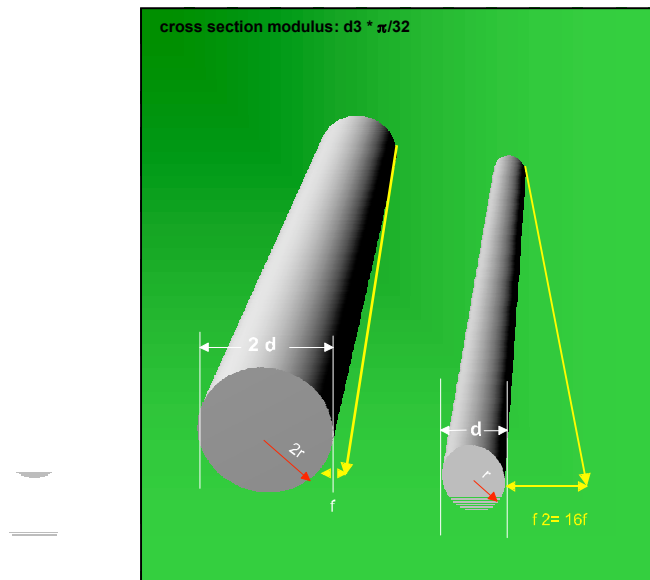

If a thin stem is connected to a thicker stem it is important to know that half diameter carries only 12,5% of the full diameter! If a weaker stem has to support a thicker predamaged one the thinner should be attached nearer to its base in order to reduce the levers. An additional connection may be installed parallel to ground level in the upper third of the crown.

Fig. 13

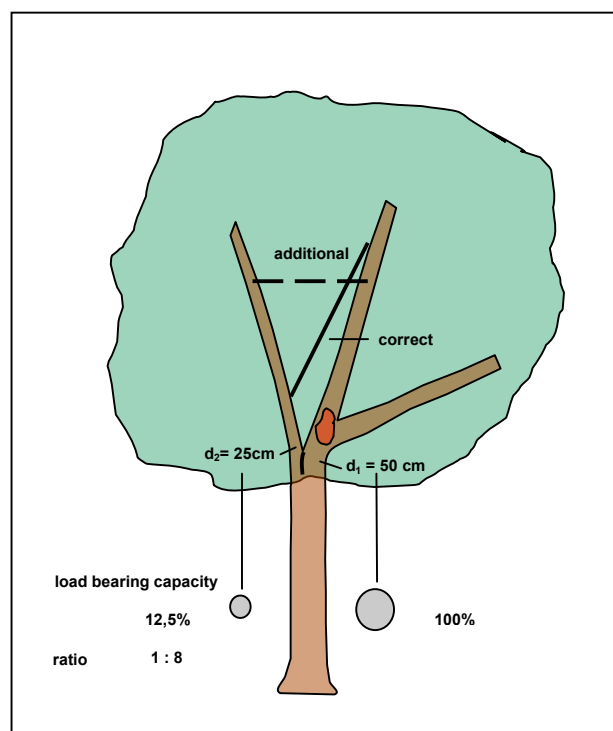

# The nine rules of correct bracing (Wessolly 1996[9])

## 1. Determination of the basic safety

Is the tree stable enough? (tipping?)  
 Is the tree safe against stem fracture?  
 Is the securing leader capable of bearing the load?

## 2. Cabling as high as possible

Reduces the forces generated in the cable, reduces costs because less strength is required of the rope. (Install at least in the upper third of the crown.)

## 3 Never connect parallel stems or branches

Do it diagonally  
 Otherwise there is no safety.

## 4 Step angles required

Securing ropes should be installed at a steep angle otherwise the horizontal branch is not safe enough

## 5. Use shock absorbing systems

They help to avoid the „Karate effect“, reduce the forces in the rope, allow less rope diameter and therefore costs can be reduced.  
 Avoid pressure on cambium, supports the production of reaction wood with a special shock absorbance especially when in low-strain movement of the tree.

## 6. For one direction - only one sling

Reduces the danger of overloading and high contact pressure. Avoids relative movement and abrasion.

## 7. Circular connection\* instead of direct connections

Prevents sideways impacting forces. At so called V-shaped codominant stems use additionally a direct connection.

## 8. Avoid abrasion

Use a friction hose

## 9 Avoid stem constriction

A good system has the ability of automatic adjustment with increasing stem diameter; at least adjustment should be possible

Incorrect

correct

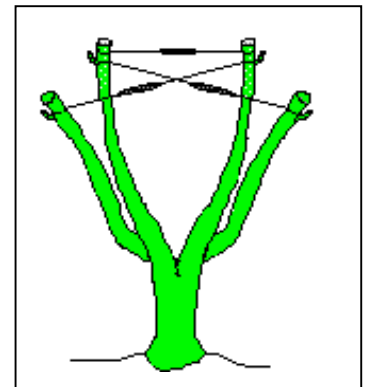
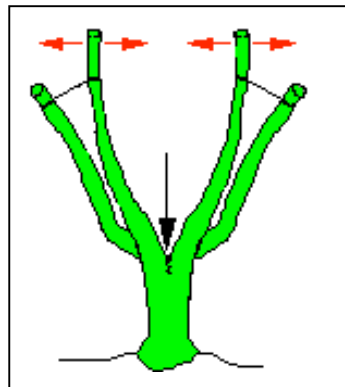

Incorrect

correct

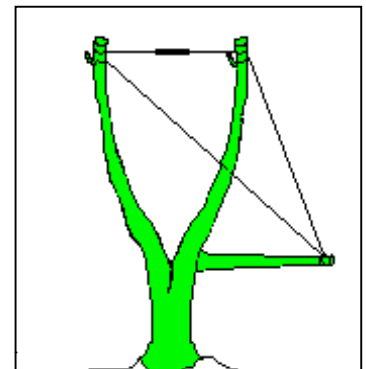
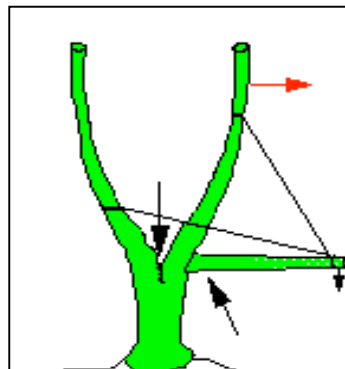

Incorrect

correct

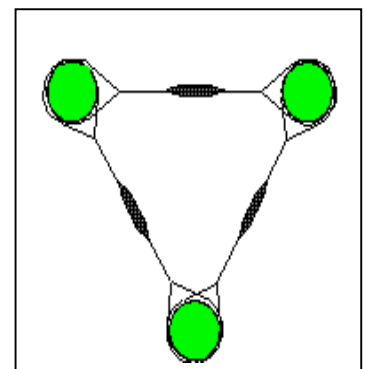
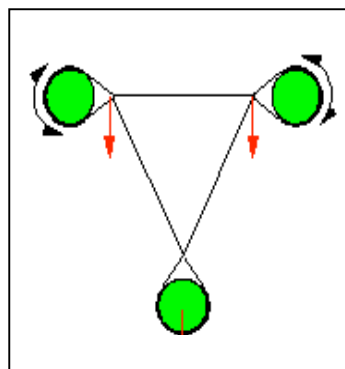

Incorrect

correct

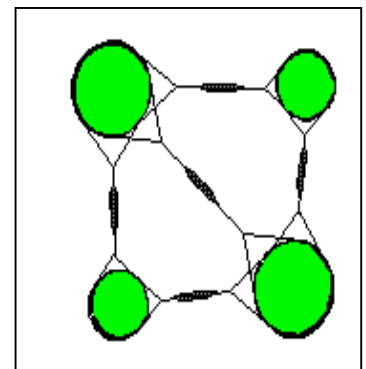
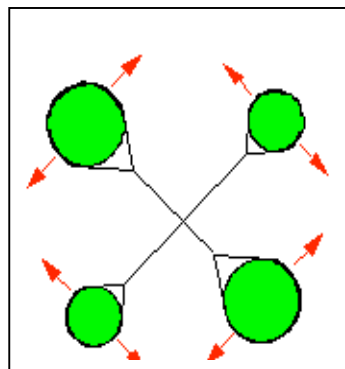

straight connection\*

circular connection\*

## Correct bracing prevents:

- Tipping, especially when slim stems can oscillate uncontrolled during storms by connecting the trees with each other
- Breaking of stems and limbs if helps to avoid exposure of central parts of the wooden body and so prevents rot and decay.
- Helps to maintain valuable heritage trees
- Helps to keep the photosynthetic biomass, instead of heavy pruning bracing and moderate pruning helps to keep the trees capacities.

## Inspections

A brake on a car is a safety device which needs to be inspected in determined periods- the same should be done with bracing systems in trees regardless whether they are modern and flexible or traditional and rigid.

Braced trees should be inspected visually at least every two years from the ground (binoculars). Detailed inspection by climbing or by a cherry picker should be done every 5 years.

Connections which were installed in steep crotches with a danger of ingrowth should be inspected in shorter periods and if necessary loosened. Belt supported systems may ingrow when the tree is growing quickly in circumference and the limit of the elastic straps is exceeded. The cobra system can be inspected by controlling the colour of the end caps, other systems can be checked by reviewing the data of installation.

## Literature References

- [1] MALEK, JOHANNES VON und WAWRIK, HEINRICH. *Baumpflege: Pflanzung und Pflege von Straßenbäumen*. Stuttgart: Ulmer, 1985
- [2] WESSOLLY, LOTHAR und ERB, MARTIN. *Handbuch der Baumstatik und Baumkontrolle*. Berlin: Patzer, 1998
- [3] VETTER, HANS und WESSOLLY, LOTHAR. Verkehrssicherheit: Vermeidung von Fehlern bei der Kronensicherung. *Das Gartenamt* 4 (1994): 611-616
- [4] PBS-BAUMSICHERUNGSPRODUKTE. Die Handhabung des cobra-Seilsystems und cobra-Seilsystem. *Produktinformationsbroschüren* (1997 und 1999)
- [5] LESNINO, GEORGES. *Mikroskopische Untersuchungen zur langzeitigen Auswirkung von cobra-Kronensicherungen auf die Holzbildung*. 1999. Untersuchungsbericht
- [6] SCHRÖDER, KLAUS. „Kronensicherung mit dem „Doppelgurtsystem Osnabrück“ – Entwicklungen und Erfahrungen seit 1990.“ *Jahrbuch der Baumpflege 1998: 170-183, Thalacker 1998.*
- [7] SCHRÖDER, KLAUS; DUJESIEFKEN, DIRK; STOBBE, HORST. *Kronensicherung mit Doppelgurten „System Osnabrück“ – Holzbiologische Untersuchungen sechs Jahre nach dem Einbau.: LA Landschaftsarchitektur 8.98:40-42.*
- [8] WESSOLLY, LOTHAR; VETTER, HANS. *Tips und Tricks bei der Kronensicherung von Bäumen, Neue Landschaft 10 (1998) 747*
- [9] WESSOLLY, LOTHAR; VETTER, HANS. *Kronensicherung in Bäumen – Neuester Stand, Stadt und Grün 7/99*
- [10] WESSOLLY, LOTHAR; *Handbuch der Baumstatik*, 1998, Patzer